

# RainSoft®

Water Treatment Systems  
Since 1953

## EC4 SERIES WATER TREATMENT SYSTEM

# Owner's Manual



This product is manufactured in an ISO 9001:2000 certified facility.



The EC4 Series is tested and certified by the WQA to NSF/ANSI Standard 44 for the specific performance claims as verified and substantiated by test data. See the performance data sheets for specific reduction claims.

# Table of Contents

Information on Water Treatment Systems .....	3
Application Limitations .....	3
Operational Specifications .....	4–6
Salt Requirements .....	7
Resin Cleaners.....	7
Maintenance Requirements.....	7
Product Certification Information.....	7
Installation Instructions .....	8–11
System Start Up.....	12
Customer Settings .....	13–14
How to Initiate a Manual Regeneration .....	14
System Alarms .....	15
Understanding the Information Center .....	15
Troubleshooting Guide .....	16
Warranty Information .....	17
Exploded Views and Parts Lists.....	18–21
California Performance Data Sheets.....	22–31

**Congratulations** on your purchase of a RainSoft water treatment system.

This Owner's Manual is designed to assist with the operation, maintenance, and installation of your water treatment system. It is our sincere hope that this manual is clear, concise, and helpful to you as a new owner.

**Questions?** If you have any questions regarding the installation, operation, or servicing of this system, please contact your local RainSoft Dealer. Your local RainSoft Dealer is familiar with your particular water conditions, and is able to address your concerns promptly and efficiently.

## Information on Water Treatment Systems

There are many misconceptions that have been developed about water treatment systems. The most common topic of confusion is the amount of sodium (Na), not table salt (NaCl), that is added to the water from a water conditioner. In reality, ion exchange does replace the hardness ions in your water with sodium ions, but the common misconception is the amount used.

For every 1 grain of hardness, the exchange process will deliver approximately 8 milligrams of sodium per 1 liter of water. The amount of sodium present in a standard 8 ounce glass of treated water, that was 10 grains hard prior to treatment, would be around 19 milligrams of sodium. This is an insignificant amount of sodium considering a typical slice of white bread has about 140 milligrams.

Another common misconception that needs mentioning is the amount of salt used by the conditioner to regenerate the system. In the past, water conditioners used more salt to regenerate, but that was due to old technology and standards. Water conditioners do use salt for regeneration, but the amount of salt varies by water consumption and hardness levels. Fortunately, today's technology allows us to dispense just the right amount of salt for maximum efficiency, based on your individual water consumption needs.

## Application Limitations

- On hardness levels of 60 grains and higher, the system may not achieve a hardness of less than 1 grain; due to high Total Dissolved Solids, some bleed through is possible. Bleed through can also be caused by sodium levels higher than 1000 parts per million. In either case, your system can be programmed to minimize these effects. See your RainSoft Dealer for details.
- Chlorine or Chloramine levels on municipality treated water should not exceed 4 parts per million.\* When Chlorine or Chloramine levels are 4 parts per million\* or greater, it can have adverse effects on your system. In applications where high levels are a concern, pre-filtration is necessary to reduce the Chlorine or Chloramine to an acceptable level. See your RainSoft Dealer for details.
- When this system is installed on water with Ferrous iron, also known as clear water iron, the maximum range of removal is based on local water conditions. The range is generally 2 to 10 parts per million. Your equipment may require special programming, along with an additive to the brine tank, to maximize the equipment's ability to remove iron. See your RainSoft Dealer for details.

 **Helpful Tip:** Another common misconception of water treatment systems is the idea that soft water will produce clear ice cubes. Cloudy or white, hazy ice cubes are caused by air that is slowly being released from the water during the freezing process, which has nothing to do with the performance of your system.

 **Important Note:** This system may be in-stalled on well water or municipality treated water supplies.

 **Important Note:** Most municipality treated water supplies contain Chlorine as a disinfectant. Many municipalities also inject ammonia into the water supply, creating Chloramine.

\* Maximum disinfectant level of Chlorine or Chloramine recommended from the EPA.

 **Important Note:** Oxidizing agents, such as Chlorine or Chloramine in excess of 4 ppm, and/or Ferrous iron will foul the resin bed. Fouled resin is not eligible for warranty replacement.

# Operational Specifications

## Plumbing

3/4 inch to 1 1/4 inch

## Drain Line

1/2 inch

## Water Pressure

20 psi–120 psi (1.38 bar – 6.89 bar)

## Operating Temperatures

40° F–100° F (4.4° C – 37.8° C)

## Electrical Requirements

A properly grounded alternating current supply (110 VAC 60 Hz or 230 VAC 50 Hz) is required for the operation of this system. Please check the transformer for the correct voltage requirements.

## Bypass Valve

The bypass valve enables you to bypass the system in situations of: emergency leaks in the equipment, service calls and/or outdoor water use.

## Existing Plumbing Conditions

Plumbing should be free from lime and/or iron buildup. Piping that contains large amounts of lime and/or iron should be replaced. If piping is clogged with iron, a separate iron filter should be installed in-line, before the water conditioner.

## Additional Specifications

- Do not install this system where water is microbiologically unsafe or of unknown quality without adequate disinfection before or after the system.
- This system must be installed in accordance with all applicable state and local laws and regulations.
- The Commonwealth of Massachusetts Plumbing Code 248 CMR shall be adhered to. A liscence plumber shall be used for this installation.
- This system must be installed in an area not affected by extreme heat, cold or the elements. The selected installation area must be adequate for easy service and accessibility.
- This system is designed to treat cold water only. The installation must be on a cold water supply.

## Data Chart for ION-X 2000 V Resin

Model	Tank Size (inches)	Resin* (cu. ft.)	Service Flow (gpm)	Drain Flow (gpm)	psi Drop	High Salting	Medium Salting	Low Salting	Efficiency**
EC4 50 V	8 x 44	0.5	10.0	1.5	14.0	18,700 @ 7.5 lbs.	16,000 @ 5.0 lbs.	8,900 @ 2.0 lbs.	4,470 @ 2.0 lbs.
EC4 50 CV	8 x 44	0.5	10.0	1.5	14.0	18,700 @ 7.5 lbs.	16,000 @ 5.0 lbs.	8,900 @ 2.0 lbs.	4,470 @ 2.0 lbs.
EC4 60SS V	10 x 18	0.6	9.5	2.0	10.0	22,000 @ 9.0 lbs.	18,700 @ 6.0 lbs.	10,500 @ 2.4 lbs.	4,370 @ 2.4 lbs.
EC4 60SS CV	10 x 18	0.6	9.5	2.0	9.0	22,000 @ 9.0 lbs.	18,700 @ 6.0 lbs.	10,500 @ 2.4 lbs.	4,370 @ 2.4 lbs.
EC4 60S V	10 x 35	0.6	9.5	2.0	10.0	22,500 @ 9.0 lbs.	19,200 @ 6.0 lbs.	10,700 @ 2.4 lbs.	4,470 @ 2.4 lbs.
EC4 60S CV	10 x 35	0.6	9.5	2.0	10.0	22,500 @ 9.0 lbs.	19,200 @ 6.0 lbs.	10,700 @ 2.4 lbs.	4,470 @ 2.4 lbs.

**! Important Note: This system requires the use of the supplied transformer (24 VAC).**

**! Important Note: The manually operated bypass valve enables the conditioner to be isolated from the water service line for maintenance and service. It also maintains the continuity of the water supply when the conditioner is disconnected.**

\* Cation Exchange Media

\*\* The conditioners are efficiency rated according to NSF/ANSI 44. The efficiency of the conditioner is valid only at the stated salt dosage.

Higher or lower pressure will affect the efficiency of the system.

\*\*\* Only the following models are certified in the State of California: EC4 75 CV, EC4 100 CV, EC4 150 CV, EC4-CAB 60 CV and EC4-CAB 100 CV. All other models are not certified in the State of California for the purpose of making health claims.

## Data Chart for ION-X 2000 V Resin

Model	Tank Size (inches)	Resin* (cu. ft.)	Service Flow (gpm)	Drain Flow (gpm)	psi Drop	High Salting	Medium Salting	Low Salting	Efficiency**
EC4 75 V	8 x 44	0.75	9.0	1.5	15.0	28,100 @ 11.2 lbs.	24,000 @ 7.5 lbs.	13,400 @ 3.0 lbs.	4,470 @ 3.0 lbs.
EC4 75 CV	8 x 44	0.75	9.3	1.5	15.0	28,100 @ 11.2 lbs.	24,000 @ 7.5 lbs.	13,400 @ 3.0 lbs.	4,470 @ 3.0 lbs.
EC4 100 V	10 x 44	1.0	10.0	2.0	13.0	37,700 @ 15.0 lbs.	32,300 @ 10.0 lbs.	14,900 @ 3.0 lbs.	4,970 @ 3.0 lbs.
EC4 100 CV	10 x 44	1.0	10.0	2.0	12.0	37,700 @ 15.0 lbs.	32,300 @ 10.0 lbs.	14,900 @ 3.0 lbs.	4,970 @ 3.0 lbs.
EC4 100S V	10 x 35	1.0	10.0	2.0	15.0	37,700 @ 15.0 lbs.	32,300 @ 10.0 lbs.	14,900 @ 3.0 lbs.	4,970 @ 3.0 lbs.
EC4 100S CV	10 x 35	1.0	10.0	2.0	12.0	37,700 @ 15.0 lbs.	32,300 @ 10.0 lbs.	14,900 @ 3.0 lbs.	4,970 @ 3.0 lbs.
EC4 150 V	10 x 54	1.5	9.0	2.0	15.0	56,600 @ 22.5 lbs.	48,500 @ 15.0 lbs.	22,400 @ 4.5 lbs.	4,970 @ 4.5 lbs.
EC4 150 CV	10 x 54	1.5	10.4	2.0	15.0	56,600 @ 22.5 lbs.	48,500 @ 15.0 lbs.	22,400 @ 4.5 lbs.	4,970 @ 4.5 lbs.
EC4 250 V	13 x 54	2.5	10.4	3.0	15.0	94,300 @ 37.5 lbs.	80,900 @ 25.0 lbs.	37,300 @ 7.5 lbs.	4,970 @ 7.5 lbs.
EC4 250 CV	13 x 54	2.5	10.5	3.0	13.0	94,300 @ 37.5 lbs.	80,900 @ 25.0 lbs.	37,300 @ 7.5 lbs.	4,970 @ 7.5 lbs.
EC4 400 V	14 x 65	4.0	10.0	4.0	15.0	141,800 @ 60.0 lbs.	121,500 @ 40.0 lbs.	56,000 @ 12.0 lbs.	4,670 @ 12.0 lbs.
EC4 400 CV	14 x 65	4.0	11.3	4.0	15.0	141,800 @ 60.0 lbs.	121,500 @ 40.0 lbs.	56,000 @ 12.0 lbs.	4,670 @ 12.0 lbs.
EC4-CAB 60SS V	10 x 18	0.6	9.5	2.0	10.0	22,000 @ 9.0 lbs.	18,700 @ 6.0 lbs.	10,500 @ 2.4 lbs.	4,370 @ 2.4 lbs.
EC4-CAB 60SS CV	10 x 18	0.6	9.5	2.0	9.0	22,000 @ 9.0 lbs.	18,700 @ 6.0 lbs.	10,500 @ 2.4 lbs.	4,370 @ 2.4 lbs.
EC4-CAB 60 V	10 x 35	0.6	9.5	2.0	10.0	22,500 @ 9.0 lbs.	19,200 @ 6.0 lbs.	10,700 @ 2.4 lbs.	4,470 @ 2.4 lbs.
EC4-CAB 60 CV	10 x 35	0.6	9.5	2.0	10.0	22,500 @ 9.0 lbs.	19,200 @ 6.0 lbs.	10,700 @ 2.4 lbs.	4,470 @ 2.4 lbs.
EC4-CAB 100 V	10 x 35	1.0	10.0	2.0	15.0	37,700 @ 15.0 lbs.	32,300 @ 10.0 lbs.	14,900 @ 3.0 lbs.	4,970 @ 3.0 lbs.
EC4-CAB 100 CV	10 x 35	1.0	10.0	2.0	12.0	37,700 @ 15.0 lbs.	32,300 @ 10.0 lbs.	14,900 @ 3.0 lbs.	4,970 @ 3.0 lbs.

\* Cation Exchange Media

\*\* The conditioners are efficiency rated according to NSF/ ANSI 44. The efficiency of the conditioner is valid only at the stated salt dosage.

Higher or lower pressure will affect the efficiency of The system.

\*\*\* Only the following models are certified in the State of California: EC4 75 CV, EC4 100 CV, EC4 150 CV, EC4-CAB 60 CV and EC4-CAB 100 CV. All other models are not certified in the State of California for the purpose of making health claims.

## Data Chart for ION-X 100 T Resin

Model	Tank Size (inches)	Resin* (cu. ft.)	Service Flow (gpm)	Drain Flow (gpm)	psi Drop	High Salting	Medium Salting	Low Salting	Efficiency**
EC4 50 T	8 x 44	0.5	10.0	1.5	12.0	12,600 @ 7.5 lbs.	10,000 @ 5.0 lbs.	5,800 @ 2.0 lbs.	n/a
EC4 50 CT	8 x 44	0.5	10.0	1.5	13.0	12,600 @ 7.5 lbs.	10,000 @ 5.0 lbs.	5,800 @ 2.0 lbs.	n/a
EC4 60SS T	10 x 18	0.6	10.0	2.0	9.0	13,900 @ 9.0 lbs.	10,900 @ 6.0 lbs.	6,300 @ 2.4 lbs.	n/a
EC4 60SS CT	10 x 18	0.6	10.0	2.0	9.0	13,900 @ 9.0 lbs.	10,900 @ 6.0 lbs.	6,300 @ 2.4 lbs.	n/a
EC4 60S T	10 x 35	0.6	10.0	2.0	10.0	15,000 @ 9.0 lbs.	11,800 @ 6.0 lbs.	6,800 @ 2.4 lbs.	n/a
EC4 60S CT	10 x 35	0.6	10.0	2.0	10.0	15,000 @ 9.0 lbs.	11,800 @ 6.0 lbs.	6,800 @ 2.4 lbs.	n/a
EC4 75 T	8 x 44	0.75	9.9	1.5	15.0	19,000 @ 11.2 lbs.	14,900 @ 7.5 lbs.	8,700 @ 3.0 lbs.	n/a
EC4 75 CT	8 x 44	0.75	10.0	1.5	15.0	19,000 @ 11.2 lbs.	14,900 @ 7.5 lbs.	8,700 @ 3.0 lbs.	n/a
EC4 100 T	10 x 44	1.0	10.0	2.0	13.0	25,800 @ 15.0 lbs.	25,700 @ 10.0 lbs.	12,200 @ 3.0 lbs.	4,070 @ 3.0 lbs.
EC4 100 CT	10 x 44	1.0	10.0	2.0	13.0	25,800 @ 15.0 lbs.	25,700 @ 10.0 lbs.	12,200 @ 3.0 lbs.	4,070 @ 3.0 lbs.
EC4 100S T	10 x 35	1.0	10.0	2.0	13.0	25,800 @ 15.0 lbs.	25,700 @ 10.0 lbs.	12,200 @ 3.0 lbs.	4,070 @ 3.0 lbs.
EC4 100S CT	10 x 35	1.0	10.0	2.0	13.0	25,800 @ 15.0 lbs.	25,700 @ 10.0 lbs.	12,200 @ 3.0 lbs.	4,070 @ 3.0 lbs.
EC4 150 T	10 x 54	1.5	9.6	2.0	15.0	38,700 @ 22.5 lbs.	38,500 @ 15.0 lbs.	18,300 @ 4.5 lbs.	4,070 @ 4.5 lbs.
EC4 150 CT	10 x 54	1.5	9.6	2.0	15.0	38,700 @ 22.5 lbs.	38,500 @ 15.0 lbs.	18,300 @ 4.5 lbs.	4,070 @ 4.5 lbs.

\* Cation Exchange Media

\*\* The conditioners are efficiency rated according to NSF/ ANSI 44. The efficiency of the conditioner is valid only at the stated salt dosage.

Higher or lower pressure will affect the efficiency of The system.

\*\*\* Only the following models are certified in the State of California: EC4 75 CV, EC4 100 CV, EC4 150 CV, EC4-CAB 60 CV and EC4-CAB 100 CV. All other models are not certified in the State of California for the purpose of making health claims.

### Data Chart for ION-X 100 T Resin

Model	Tank Size (inches)	Resin* (cu. ft.)	Service Flow (gpm)	Drain Flow (gpm)	psi Drop	High Salting	Medium Salting	Low Salting	Efficiency**
EC4 250 T	13 x 54	2.5	11.4	3.0	15.0	64,500 @ 37.5 lbs.	64,200 @ 25.0 lbs.	30,500 @ 7.5 lbs.	4,070 @ 7.5 lbs.
EC4 250 CT	13 x 54	2.5	11.2	3.0	15.0	64,500 @ 37.5 lbs.	64,200 @ 25.0 lbs.	30,500 @ 7.5 lbs.	4,070 @ 7.5 lbs.
EC4 400 T	14 x 65	4.0	10.8	4.0	15.0	97,500 @ 60.0 lbs.	97,000 @ 40.0 lbs.	46,200 @ 12.0 lbs.	3,850 @ 12.0 lbs.
EC4 400 CT	14 x 65	4.0	10.7	4.0	15.0	97,500 @ 60.0 lbs.	97,000 @ 40.0 lbs.	46,200 @ 12.0 lbs.	3,850 @ 12.0 lbs.
EC4-CAB 60 T	10 x 35	0.6	10.0	2.0	10.0	15,000 @ 9.0 lbs.	11,800 @ 6.0 lbs.	6,800 @ 2.4 lbs.	n/a
EC4-CAB 60 CT	10 x 35	0.6	10.0	2.0	10.0	15,000 @ 9.0 lbs.	11,800 @ 6.0 lbs.	6,800 @ 2.4 lbs.	n/a
EC4-CAB 60SS T	10 x 18	0.6	10.0	2.0	9.0	13,900 @ 9.0 lbs.	10,900 @ 6.0 lbs.	6,300 @ 2.4 lbs.	n/a
EC4-CAB 60SS CT	10 x 18	0.6	10.0	2.0	9.0	13,900 @ 9.0 lbs.	10,900 @ 6.0 lbs.	6,300 @ 2.4 lbs.	n/a
EC4-CAB 100 T	10 x 35	1.0	10.0	2.0	13.0	25,800 @ 15.0 lbs.	25,700 @ 10.0 lbs.	12,200 @ 3.0 lbs.	4,070 @ 3.0 lbs.
EC4-CAB 100 CT	10 x 35	1.0	10.0	2.0	13.0	25,800 @ 15.0 lbs.	25,700 @ 10.0 lbs.	12,200 @ 3.0 lbs.	4,070 @ 3.0 lbs.

\* Cation Exchange Media

\*\* The conditioners are efficiency rated according to NSF/ANSI 44. The efficiency of the conditioner is valid only at the stated salt dosage.

Higher or lower pressure will affect the efficiency of the system.

\*\*\* Only the following models are certified in the State of California: EC4 75 CV, EC4 100 CV, EC4 150 CV, EC4-CAB 60 CV and EC4-CAB 100 CV. All other models are not certified in the State of California for the purpose of making health claims.

### Data Chart for ION-X 34 D Resin

Model	Tank Size (inches)	Resin* (cu. ft.)	Service Flow (gpm)	Drain Flow (gpm)	psi Drop	High Salting	Medium Salting	Low Salting	Efficiency**
EC4 50 D	8 x 44	0.5	10.0	1.5	13.0	16,000 @ 7.5 lbs.	10,800 @ 5.0 lbs.	7,800 @ 2.0 lbs.	3,920 @ 2.0 lbs.
EC4 50 CD	8 x 44	0.5	10.0	1.5	13.0	16,000 @ 7.5 lbs.	10,800 @ 5.0 lbs.	7,800 @ 2.0 lbs.	3,920 @ 2.0 lbs.
EC4 60SS D	10 x 18	0.6	10.0	2.0	10.0	17,500 @ 9.0 lbs.	11,900 @ 6.0 lbs.	8,600 @ 2.4 lbs.	3,580 @ 2.4 lbs.
EC4 60SS CD	10 x 18	0.6	10.0	2.0	10.0	17,500 @ 9.0 lbs.	11,900 @ 6.0 lbs.	8,600 @ 2.4 lbs.	3,580 @ 2.4 lbs.
EC4 60S D	10 x 35	0.6	10.0	2.0	10.0	18,900 @ 9.0 lbs.	12,900 @ 6.0 lbs.	9,300 @ 2.4 lbs.	3,870 @ 2.4 lbs.
EC4 60S CD	10 x 35	0.6	10.0	2.0	10.0	18,900 @ 9.0 lbs.	12,900 @ 6.0 lbs.	9,300 @ 2.4 lbs.	3,870 @ 2.4 lbs.
EC4 75 D	8 x 44	0.75	9.3	1.5	15.0	24,000 @ 11.2 lbs.	16,300 @ 7.5 lbs.	11,800 @ 3.0 lbs.	3,920 @ 3.0 lbs.
EC4 75 CD	8 x 44	0.75	6.8	1.5	9.0	24,000 @ 11.2 lbs.	16,300 @ 7.5 lbs.	11,800 @ 3.0 lbs.	3,920 @ 3.0 lbs.
EC4 100 D	10 x 44	1.0	10.0	2.0	10.0	29,400 @ 15.0 lbs.	23,900 @ 10.0 lbs.	10,900 @ 3.0 lbs.	3,630 @ 3.0 lbs.
EC4 100 CD	10 x 44	1.0	10.0	2.0	10.0	29,400 @ 15.0 lbs.	23,900 @ 10.0 lbs.	10,900 @ 3.0 lbs.	3,630 @ 3.0 lbs.
EC4 100S D	10 x 35	1.0	10.0	2.0	10.0	29,400 @ 15.0 lbs.	23,900 @ 10.0 lbs.	10,900 @ 3.0 lbs.	3,630 @ 3.0 lbs.
EC4 100S CD	10 x 35	1.0	10.0	2.0	10.0	29,400 @ 15.0 lbs.	23,900 @ 10.0 lbs.	10,900 @ 3.0 lbs.	3,630 @ 3.0 lbs.
EC4 150 D	10 x 54	1.5	10.2	2.0	12.0	44,000 @ 22.5 lbs.	35,900 @ 15.0 lbs.	16,400 @ 4.5 lbs.	3,630 @ 4.5 lbs.
EC4 150 CD	10 x 54	1.5	7.8	2.0	8.0	44,000 @ 22.5 lbs.	35,900 @ 15.0 lbs.	16,400 @ 4.5 lbs.	3,630 @ 4.5 lbs.
EC4 250 D	13 x 54	2.5	12	3.0	13.0	73,400 @ 37.5 lbs.	59,800 @ 25.0 lbs.	27,300 @ 7.5 lbs.	3,630 @ 7.5 lbs.
EC4 250 CD	13 x 54	2.5	12	3.0	13.0	73,400 @ 37.5 lbs.	59,800 @ 25.0 lbs.	27,300 @ 7.5 lbs.	3,630 @ 7.5 lbs.
EC4 400 D	14 x 65	4.0	11.8	4.0	13.0	109,900 @ 60.0 lbs.	89,500 @ 40.0 lbs.	40,800 @ 12.0 lbs.	3,400 @ 12.0 lbs.
EC4 400 CD	14 x 65	4.0	9.5	4.0	9.0	109,900 @ 60.0 lbs.	89,500 @ 40.0 lbs.	40,800 @ 12.0 lbs.	3,400 @ 12.0 lbs.
EC4-CAB 60SS D	10 x 18	0.6	10.0	2.0	10.0	17,500 @ 9.0 lbs.	11,900 @ 6.0 lbs.	8,600 @ 2.4 lbs.	3,580 @ 2.4 lbs.
EC4-CAB 60SS CD	10 x 18	0.6	10.0	2.0	10.0	17,500 @ 9.0 lbs.	11,900 @ 6.0 lbs.	8,600 @ 2.4 lbs.	3,580 @ 2.4 lbs.
EC4-CAB 60 D	10 x 35	0.6	10.0	2.0	10.0	18,900 @ 9.0 lbs.	12,900 @ 6.0 lbs.	9,300 @ 2.4 lbs.	3,870 @ 2.4 lbs.
EC4-CAB 60 CD	10 x 35	0.6	10.0	2.0	10.0	18,900 @ 9.0 lbs.	12,900 @ 6.0 lbs.	9,300 @ 2.4 lbs.	3,870 @ 2.4 lbs.
EC4-CAB 100 D	10 x 35	1.0	10.0	2.0	10.0	29,400 @ 15.0 lbs.	23,900 @ 10.0 lbs.	10,900 @ 3.0 lbs.	3,630 @ 3.0 lbs.
EC4-CAB 100 CD	10 x 35	1.0	10.0	2.0	10.0	29,400 @ 15.0 lbs.	23,900 @ 10.0 lbs.	10,900 @ 3.0 lbs.	3,630 @ 3.0 lbs.

\* Cation Exchange Media

\*\* The conditioners are efficiency rated according to NSF/ANSI 44. The efficiency of the conditioner is valid only at the stated salt dosage.

Higher or lower pressure will affect the efficiency of the system.

\*\*\* Only the following models are certified in the State of California: EC4 75 CV, EC4 100 CV, EC4 150 CV, EC4-CAB 60 CV and EC4-CAB 100 CV. All other models are not certified in the State of California for the purpose of making health claims.

## Salt Requirements

Two salt types are recommended for water conditioners:

**Block Salt:** Water conditioner block salt is reasonably priced, low in impurities, and will not cake in the salt container.

**Solar Salt:** Solar salt is reasonably priced and low in impurities.

## Resin Cleaners

It is always wise to provide preventative maintenance for your system. If small amounts of iron are present in your water, use a salt containing iron remover or add RainSoft water conditioner cleaner to the salt tank when adding salt. If an excessive amount of iron is present in your water, we recommend the installation of an iron filter before the conditioner. See your RainSoft Dealer for details.

## Maintenance Requirements

### Cleaning the Regeneration Valve

The regeneration valve body is designed to last a lifetime, but from time to time it may be necessary to clean and lubricate the moving parts. Your water quality and the amount of regenerations necessary will affect this maintenance schedule. Your local RainSoft Dealer is knowledgeable in the different water qualities and will have the necessary parts to complete this service.

### Testing Your Water

If you are relying on this system for barium and radium reduction, we recommend testing your water periodically (2 times a year) with a hardness test strip (supplied) to ensure that the system is performing properly, and that hardness, barium, and radium are being reduced\*. Additional hardness test strips are available at no charge from RainSoft. Please call 1-800-860-7638 for your free two year supply.

In between testing, you can easily monitor the system's performance in the shower or while washing your hands. The feeling of soft water should be present on your skin.

## Product Certification Information

The EC4 Series is tested and certified by the WQA to NSF/ANSI Standard 44 for the specific performance claims as verified and substantiated by test data. Please refer to the performance data sheets for specific reductions claims.

Water treatment devices sold to retail consumers in California, accompanied by certain health claims, must be certified by the State of California Department of Health Services.

Models EC4 75 CV (certificate #06-1803), EC4 100 CV (certificate #06-1802), EC4 150 CV (certificate #06-1801), EC4-CAB 60 CV (certificate #06-1805) and EC4-CAB 100 CV (certificate #06-1804) are certified in California. All other models are not certified in the State of California for the purpose of making health claims. For health claims certified by the State of California Department of Health Services, conditions of use and replacement parts, please refer to the California performance data sheets on pages 22—31.

**! Important Note: Rock salt is not recommended for RainSoft water conditioners. If rock salt is used, the salt container must be cleaned out periodically. DO NOT USE GRANULATED SALT! The use of granulated salt may cause service problems.**

**! Helpful Tip: Resin cleaner will prevent the treatment media from becoming iron fouled.**

**! Important Note: If you use a cleaner containing nitric acid or other strong oxidizing agents, please use caution and follow instructions carefully.**

**! Helpful Tip: We recommend that this service be performed every three years or earlier if necessary.**

**! Important Note: The supplied test strip only tests for hardness. A reduction of hardness is also an indication that barium and radium are being reduced\*.**

**\* Only the following models are certified for barium and radium reduction in the State of California: EC4 75 CV, EC4 100 CV, EC4 150 CV, EC4-CAB 60 CV and EC4-CAB 100 CV. All other models are not certified in the State of California for the purpose of making health claims.**

# Installation Instructions

## 1. Safety Precautions

- To prevent an accident and/or injury, do not hoist the unit over your shoulder. Use a hand truck to transport the unit.
- Do not lay the unit on its side.
- Wear safety glasses and work gloves during installation.

## 2. Test the Raw Water

- Test the raw water for hardness, iron and/or any other element that could affect the performance of the system.

## 3. Check the Water Pressure

- Use a pressure gauge to confirm that the water pressure does not exceed 120 psi. If the water pressure does exceed this limit, install a pressure regulator on the inlet pipe of the unit. The minimum water pressure for a conditioner is 20 psi. 60 psi is the optimum operating pressure.

## 4. Locate a Site for the System

- There are three primary requirements needed for a site: the main water source, a drain and an electrical connection. Locate the system as close to these items as practical. Avoid drain lines over 25 feet long. In most applications, bypass any outside faucets.
- Place the system in the desired location. The location should have a level, smooth, and clean surface.
- If the system is located outdoors, protect the unit from direct sunlight. Direct sunlight can damage the fiberglass and other system components. If necessary, build a box or shed.

 **Helpful Tip: The drain may be a floor drain, a sewer trap, utility sink, vent stack, dry well, etc., depending on local plumbing codes.**

## 5. Install the Valve Head

- Remove the cap plug from the tank.
- Lubricate the riser pipe o-ring and tank o-ring with the proper silicone lubricant.
- Attach the supplied upper basket to the bottom of the control valve; twist to lock in place.
- Align the upper basket with the riser pipe and slowly lower the control valve onto the riser pipe, using a twisting motion.
- Align the control valve with the tank. Push down on the control valve and continue to turn it clockwise until the valve o-ring seals against the tank.

 **Important Note: The system can only be installed outdoors in climates that do not reach freezing levels.**

 **Important Note: Not Applicable for EC4-CAB and SS Models.**

## 6. Turn Off the Water and Drain the Plumbing

- Turn off the water at the meter or the pressure tank.
- To drain the plumbing system, open all faucets in the house and flush the toilets. The water will drain out of the lowest faucet or outlet.
- Do not sweat pipes with water in them or while attached to the system; steam will damage the plastic parts in the valve.
- Do not point the soldering torch directly at the mineral tank or control valve. These composite materials will last a lifetime, but cannot withstand the intense heat from a torch.

 **Important Note: Do not over-tighten the valve to the tank.**

 **Helpful Tip: This procedure will allow air to enter the plumbing system.**

 **Important Note: Applicable for copper plumbing installations.**



- Avoid short connections of pipe between the system and the water heater. If you can't avoid a short connection, move the system to another location. As a last resort, install a heat trap or check valve. If this causes "water hammer", install a water hammer suppressor.

## 7. Bypass the Outside Faucets

- Install plumbing pipes to bypass the outside faucet(s). If the plumbing is not accessible, provide an untreated hose bib on the inlet pipe.

## 8. Install the Pipe Connector (Yoke) to the Bypass Valve

- Once the plumbing is complete, connect the yoke to the bypass

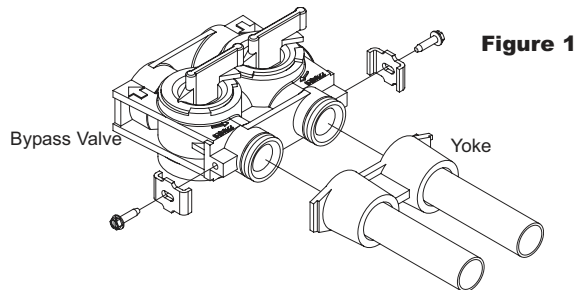

valve (see figure 1).

- Support all plumbing connected to the yoke.
- Connect the raw water supply to the inlet pipe connection of the yoke. When looking at the front of the system, the inlet is the pipe connection on the right side of the valve (see figure 2). The arrow molded into valve indicates the direction of flow.
- Connect the treated water pipe to the outlet pipe connection on the yoke. When looking at the front of the system, the outlet is the pipe connection on the left side of the valve (see figure 2). The arrow molded into the valve indicates the direction of flow.

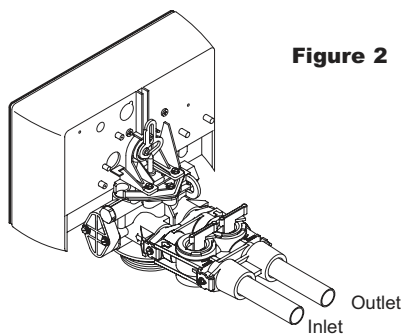

## 9. Set the Bypass Valve to Bypass

- Move the bypass valve handles to the bypass position. The valve handles should be perpendicular to the pipes (see figure 3).

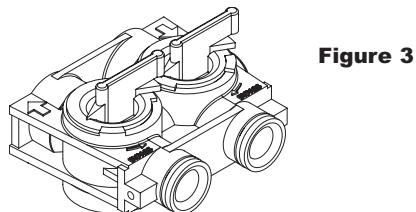

**! Important Note: Short connections of pipe may allow hot water to back up into the system.**

**! Important Note: The bypass valve is not designed to withstand heat from soldering or twisting from the attached threaded connections.**

**! Important Note: Too much weight on the plumbing connections will cause a leak.**

## 10. Install the Drain Line and Air Gap (Air Gap Not Supplied)

- For all drain lines, use at least a 1/2 inch ID line.
- Connect the drain line to the drain outlet on back of the valve, opposite the inlet connection (see figure 4). A fitting is required to

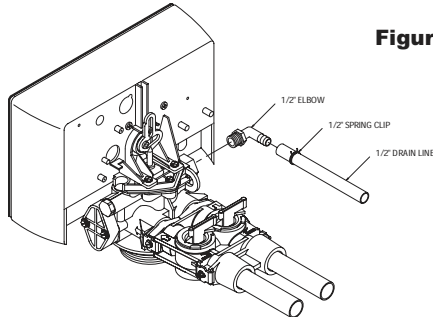

Figure 4

connect the female pipe thread to the drain line.

- Run the drain line to the air gap. The air gap must be installed between the end of the drain line and the drain to prevent possible

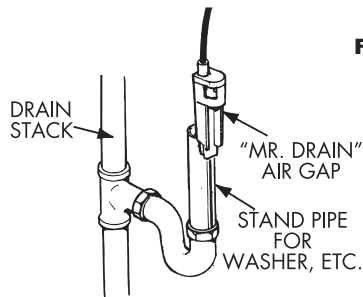

Figure 5

back siphoning (see figure 5).

**! Important Note: The air gap should be two times the diameter of the drain line or a minimum of two inches. Please check your local plumbing codes to ensure compliance.**

**! Important Note: Not Applicable for EC4-CAB Models.**

## 11. Install the Brine Safety Float

- Insert the brine well into the brine tank (see figure 6).
- Attach the brine well to the brine tank with the overflow elbow (see figure 6).

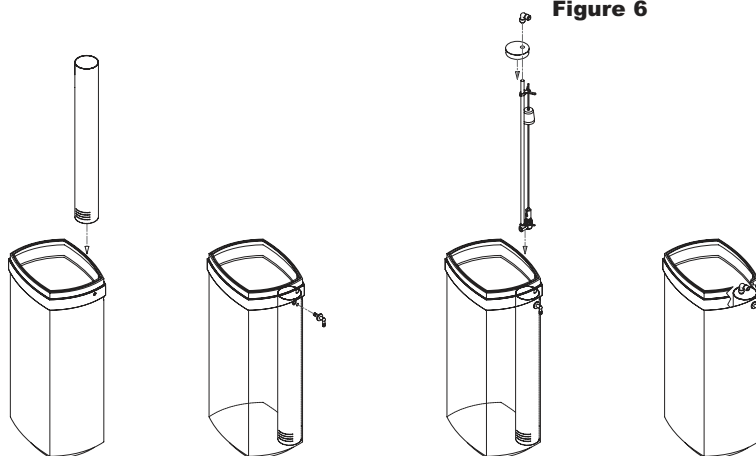

Figure 6

## 12. Install the Brine Line

- Slide the brass compression nut over the end of the brine line, followed by the ferrule and tube support. Attach the brine line to the brass fitting on the right side of the valve (see figure 7).
- Insert a tube support into the other end of the brine line and push the brine line into the brine safety float elbow. Use a locking clip to secure the connection (see figure 7).

## 13. Install the Brine Overflow Line

- Run a 1/2 inch brine overflow line from the overflow elbow on the side of the brink tank to an approved air gap device and suitable floor drain. Use a drain clip to secure the connection (see figure 7).

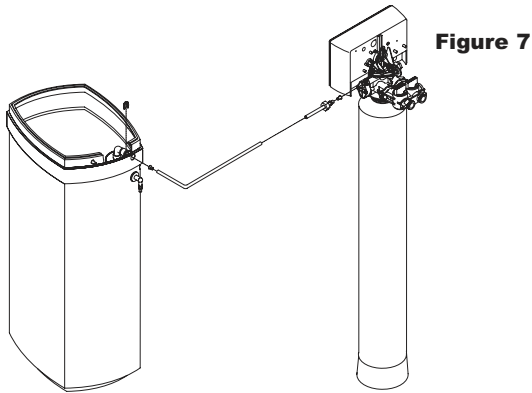

## 14. Attach the Electrical Connection

- Remove the supplied wire from the warranty pack.
- Attach the U shaped connectors (supplied) to the wire with a crimping tool (not supplied).
- Connect the wire to the transformer (see figure 8).
- Insert the other end of the wire, with the connector, into the back of the control box (see figure 8).
- Plug the transformer into a 110 VAC 60 Hz or 230 VAC 50 Hz outlet.

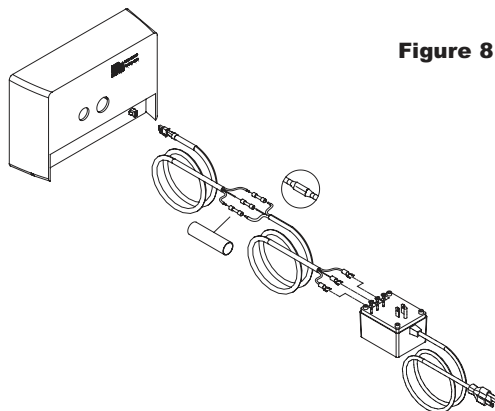

**! Important Note: Not Applicable for EC4-CAB Models.**

**! Important Note for EC4-CAB Models: The overflow elbow is located on the back of the brine tank (not shown).**

**! Important Note: The brine overflow line must not be higher than the overflow elbow on the brink tank. (This is a gravity overflow.)**

**! Helpful Tip: If the wire is too short, use the supplied connectors and shrink tubing in the warranty pack to lengthen the wire.**

**! Helpful Tip: Squeeze the connector to release it from the box.**

**! Helpful Tip: Check the transformer label for the correct voltage requirement.**

- Insert the safety float into the brine well. The top of the safety float should be about 5 inches from the overflow elbow (see figure 6).

## System Start Up

### 1. Turn on the Water and Check for Leaks

- Close all faucets and turn the water back on at the water meter or pressure tank.
- Check for leaks. If a leak is present, drain the plumbing again before soldering.

### 2. Flush the Remaining Debris from the System

- Open the cold water faucet on your bathtub.
- Allow the system to flush the remaining dirt and debris into the bathtub, until the water runs clear.
- Open all remaining faucets and allow the plumbing to release any trapped air in the system.
- Close all of the faucets.

**Helpful Tip:** This procedure will prevent dirt and debris from entering the valve.

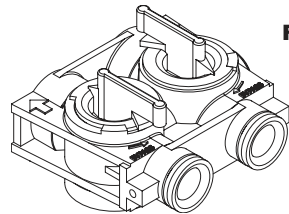

Figure 9

### 3. Open the Bypass Valve

- Move the bypass valve handles to the service position. The valve handles should be parallel to the pipes (see figure 9).
- Open the bathtub faucet again and allow the system to fill with water for approximately 5 minutes. After 5 minutes, test for soft water.

**Helpful Tip:** It is common for new systems to have some color in the water. The color should disappear after you completely flush the system.

### 4. Flush the Hot Water Heater

- Run hot water in the bathtub until the water tests soft.

### 5. Add Salt and Program the Computer

- Please refer to the “Customer Settings” on pages 13–14.

### 6. Sanitize the Conditioner

- Mix a 3/4 cup of common (unscented) 5.25% household bleach with 1 quart of water. Pour this solution into the brine well.
- Initiate a manual regeneration. The solution will be drawn into the conditioner during the regeneration process.
- After the system has completed a manual regeneration, the conditioner will be sanitized and ready for use.

**Important Note:** Do not pour undiluted bleach into the water conditioner.

# Customer Settings



The Customer Settings mode allows access to a variety of programming options:

**Salt Level:** This function sets the level of salt in the salt tank.

**Vacation Mode:** This function puts the system into hibernation while you are on vacation or gone for extended period of time.

**Salt Alarm:** This function sets the audio and visual alarms to be active and the time they will sound or inactive with no sound.

**Time of Day:** This function sets the current time of day.

**Current Day:** This function sets the current day of the week.

**Current Date:** This function sets the current date by month/day/year.

**Auto Daylight Savings Time:** This function allows the computer to automatically adjust for daylight savings time in applicable areas.

**Time of Regeneration:** This function sets the time of day (only on the hour) that the computer will regenerate the system, based on the parameters set.

**To access these programming options, please follow the directions listed below.**

If the display is not lit, press any key to begin. When the display is lit, press the Customer Settings key. Use the Menu Forward and Menu Back keys to scroll to the parameter you wish to set or change. To exit the Customer Settings function at any time, press the Enter key.

## The computer will display: Salt Level

- Fill the salt tank (to level 4) with solar salt, block salt, or potassium chloride.
- Use the Adjust Up and Adjust Down keys to change the amount of salt to the level indicated on the salt tank scale (located on the side of the salt tank).

## The computer will display: Vacation Mode – OFF

- Use the Adjust Up or Adjust Down key to select “ON”.
- If you selected “ON”, press the Enter key. The computer will display: Days Away – 2 Days.
- Use the Adjust Up and Adjust Down keys to change the number of days away.

**! Important Note:** When you exit the Customer Settings, the computer will automatically save any changes that have occurred.

**📎 Helpful Tip:** The scale for block salt is designated by levels 1 – 4. The scale for bag salt or potassium chloride is designated by levels 1 – 5. For larger tanks, a salt scale sticker is available through your RainSoft Dealer, part number 19024.

**! Important Notes:** After setting the vacation mode, the computer will provide a 16 hour delay for your convenience. If water use is detected after the 16 hour delay, the vacation mode is deactivated. One day prior to the scheduled return, the system will regenerate at the normal regeneration time. This feature will ensure a fresh conditioner bed upon your arrival.

### The computer will display: Salt Alarm – ON

- Use the Adjust Up or Adjust Down key to select “OFF”.
- If you chose to keep the alarm “ON”, press the Menu Forward key. Use the Adjust Up and Adjust Down keys to change the alarm time, if desired.

 **Helpful Tip: Your system is designed to alert you when the salt tank needs to be refilled. Select an alarm time that is most convenient for you.**

### The computer will display: Time of Day

- Use the Adjust Up and Adjust Down keys to change the hour of day.
- Press the Menu Forward key to access the minutes of day. Use the Adjust Up and Adjust Down keys to change the minutes.

 **Helpful Tip: Use the Menu Back key to edit your selection.**

### The computer will display: Current Day

- Use the Adjust Up and Adjust Down keys to select the current day.

### The computer will display: Current Date

- Use the Adjust Up and Adjust Down keys to change the month.
- Press the Menu Forward key to access the day. Use the Adjust Up and Adjust Down keys to change the day.
- Press the Menu Forward key to access the year. Use the Adjust Up and Adjust Down keys to change the year.

 **Helpful Tip: Use the Menu Back key to edit your selection.**

### The computer will display: Auto Daylight Savings Time – ON

- Use the Adjust Up or Adjust Down key to select “OFF”.

### The computer will display: Time of Regen

- Use the Adjust Up or Adjust Down key to change the hour of regeneration.

 **Helpful Tip: If auto daylight savings time is “ON”, the system will automatically adjust the clock in the spring and fall. Only set the daylight savings time to “OFF” if daylight savings time is not observed in your area.**

To exit the Customer Settings, press the Enter key.

## How to Initiate a Manual Regeneration

If the display is not lit, press any key to begin. When the display is lit, press the Manual Regen key.

### The computer will display: Manual Regen Now or Later?

- To select “Now”, press the Enter key. The computer will provide a 10 second count down before regeneration. To cancel the Now manual regeneration, use the Menu Forward key to exit the menu before the regeneration begins. If the manual regeneration has already begun, the system must complete the regeneration and then return to service before interaction with the computer can resume.
- To select “Later”, press the Menu Forward key and then the Enter key. The computer will display: Manual Regen Later at (set regeneration time).

To exit the Manual Regeneration Mode, use the Menu Forward or Menu Back key.

# System Alarms

Your system is equipped with several alarm tones: low salt, no salt, and service required. Please see below for information on the alarms:

**Salt Alarms:** When your system's salt alarm sounds, you will have the option of refilling the salt tank now or postponing the alarm until later. To add salt now, follow the onscreen prompts. To postpone the alarm, use the **Adjust Up** and **Adjust Down** keys to select the number of days you wish to postpone the alarm. Press the **Enter** key after the number of days has been selected.

**Service Required Alarms:** Please contact your local RainSoft Dealer for service.

## Understanding the Information Center

The Information Center provides current alarm information, water usage, and general information about your system. To access this information, please follow the directions listed below.

If the display is not lit, press any key to begin. When the display is lit, press the **Info. Center** key. To view the list of diagnostics, use the **Menu Forward** and **Menu Back** keys. To exit the Information Center at any time, press the **Enter** key.

The following items are displayed in the Information Center:

**Model Size:** Displays the customer's model information.

**System Status:** Displays the system's current status, including any alarm information.

**Regeneration Method:** Demand initiate is the only option.

**Salt Level:** Displays the current salt level.

**Salt Alarm:** Displays the "ON/OFF" condition and the time set to sound the salt alarm.

**Time of Regen:** Displays the hour set for regeneration.

**Avg. Water Use:** Displays the average water use of the system in gallons per day.

**Avg. Weekly Salt Used:** Displays the average weekly salt used in pounds.

**Current Flow Rate:** Displays the flow rate through the system when water is being used in gallons per minute.

**Current Water Used:** Displays the current gallon count since the last regeneration.

**Hardness:** Displays the programmed hardness in grains based on the water analysis.

**Iron:** Displays the programmed iron in parts per million based on the water analysis.

**Est. Next Regen =:** Displays the estimated number of days until the next regeneration.

**Vacation Mode:** Displays the "ON/OFF" condition.

**Conditioner Installed:** Displays the date of installation.

**Filter Installed (if applicable):** Displays the date of installation.

**Drinking Water Installed (if applicable):** Displays the date of installation.

**AirMaster Installed (if applicable):** Displays the date of installation.

**Web Address:** Displays the RainSoft web address.

**For Service Call:** Displays the service phone number.

**To exit the Information Center, press the Enter key.**

 **Helpful Tip: To silence the alarms, press any key.**

 **Helpful Tip: Disabling the alarm is not required if you add salt before the selected number of postponement days.**

**Please refer to the "Customer Settings" on page 13 for instructions on adding salt.**

 **Important Note: The Information Center is a display only mode and will not allow any changes to the settings or current service run data.**

 **Important Note: The average water use will be accurate 7 days after start up.**

 **Important Note: This is a live function and will count up as the gallons are used.**

 **Important Note: This estimate is based on water consumption. It may take 14 days after start up to provide an accurate estimate.**

# Troubleshooting Guide

Symptom	Cause	Solution
1. The system fails to regenerate automatically	<ol style="list-style-type: none"> <li>The power supply is plugged into intermittent or dead power source.</li> <li>The system is not counting gallons.</li> </ol>	<ol style="list-style-type: none"> <li>Connect to a constant power source.</li> <li>Call your RainSoft Dealer for service.</li> </ol>
2. The system regenerates at the wrong time	<ol style="list-style-type: none"> <li>The computer is not set properly.</li> <li>The time is off due to daylight savings.</li> <li>The maximum system capacity has been exceeded.</li> </ol>	<ol style="list-style-type: none"> <li>Reset the time of day/hour of regeneration.</li> <li>Verify that auto daylight savings time is set to "ON".</li> <li>Limit water usage until the regeneration is complete.</li> </ol>
3. Poor water quality	<ol style="list-style-type: none"> <li>The raw water has changed.</li> <li>The bypass valve is open.</li> <li>The power supply is disconnected.</li> </ol>	<ol style="list-style-type: none"> <li>Call your RainSoft Dealer for a new water analysis.</li> <li>Close the bypass valve.</li> <li>Plug in the power supply.</li> </ol>
4. Loss of water pressure	<ol style="list-style-type: none"> <li>Low pressure to the unit.</li> </ol>	<ol style="list-style-type: none"> <li>Bypass the system. If the problem still exists after bypass, it is not related to a RainSoft product. (Check your water distribution system.) If the problem is resolved after bypass, call your RainSoft Dealer for service.</li> </ol>
5. Excessive water in the brine tank and/or salty water	<ol style="list-style-type: none"> <li>The drain line is plugged/restricted.</li> <li>The brine valve is dirty.</li> <li>Low inlet pressure.</li> <li>The injector is plugged.</li> </ol>	<ol style="list-style-type: none"> <li>Check the water flow to the drain. Check for crimps in the drain line. Call your RainSoft Dealer for service.</li> <li>Call your RainSoft Dealer for service.</li> <li>Call your RainSoft Dealer for assistance.</li> <li>Call your RainSoft Dealer for service.</li> </ol>
6. The system fails to use salt	<ol style="list-style-type: none"> <li>The drain line is plugged/restricted.</li> <li>The injector is plugged.</li> <li>Low inlet pressure.</li> <li>No water in the brine tank.</li> </ol>	<ol style="list-style-type: none"> <li>Check the water flow to the drain. Check for crimps in the drain line. Call your RainSoft Dealer for service.</li> <li>Call your RainSoft Dealer for service.</li> <li>Call your RainSoft Dealer to increase the inlet pressure. It must be a minimum of 20 psi.</li> <li>Call your RainSoft Dealer for service.</li> </ol>
7. Constant flow to the drain	<ol style="list-style-type: none"> <li>Foreign material in the valve.</li> <li>Excessive water pressure.</li> </ol>	<ol style="list-style-type: none"> <li>Call your RainSoft Dealer to clean the valve.</li> <li>Install a pressure regulator.</li> </ol>

If the troubleshooting guide did not resolve the symptom, please contact your local RainSoft Dealer for service. If you cannot locate your local RainSoft Dealer, please contact RainSoft Customer Service at 1-800-860-7638 or logon to [www.rainsoft.com](http://www.rainsoft.com) for the name and location of your nearest authorized Dealer.



# *Limited Lifetime Warranty*

*For as long as you own the equipment*

RainSoft Division of Aquion Water Treatment Products, believing its

## **WATER TREATMENT SYSTEM**

to be of exceptional quality, hereby warrants said equipment to its first purchaser at retail as follows:

**THE TREATMENT TANK, VALVE AND SALT CONTAINER ARE WARRANTED AGAINST DEFECTS IN MANUFACTURE FOR THE LIFETIME OF THE FIRST PURCHASER AT RETAIL.**

**THE ELECTRICAL PARTS ARE WARRANTED AGAINST DEFECTS IN MANUFACTURE FOR FIVE YEARS AND PRO-RATA WARRANTED FOR AN ADDITIONAL FIVE YEARS.**

### **RESINS:**

**ION-X 34 IS WARRANTED AGAINST DEFECTS IN MANUFACTURE FOR TEN YEARS.**

**ION-X 100 IS WARRANTED AGAINST DEFECTS IN MANUFACTURE FOR THE LIFETIME OF THE FIRST PURCHASER AT RETAIL.**

**ION-X 2000 IS WARRANTED AGAINST DEFECTS IN MANUFACTURE FOR THE LIFETIME OF THE FIRST PURCHASER AT RETAIL.**

This warranty begins at the time the equipment is first connected for use, and is contingent upon the return of a signed owner's registration card.

This warranty does not require replacement of the entire unit. If the equipment does not perform properly, you should request service from the dealer that sold you the equipment. If you are not satisfied, you should notify our Customer Service Manager. If we are not able to arrange local servicing, you should send the defective part(s) (or, if you prefer, send the entire unit,) directly to the manufacturer, freight prepaid, with proof of purchase and a copy of this warranty. The defective part(s) (or entire unit) will either be repaired or new RainSoft part(s) furnished, for a nominal charge to cover labor, handling, packing and the increase, if any, in the retail price of the part(s) since the date of purchase. Genuine RainSoft parts must be used. Failure to use genuine RainSoft parts will void the warranty and certifications.

This warranty does not include labor charges, and does not cover installation, transportation, or any other claims or torts. Some states do not allow the exclusion or limitation of incidental or consequential damages, so parts of the above limitation or exclusion may not apply to you.

This warranty gives you specific legal rights, and you may also have other rights which vary from state to state. You also have implied warranty rights. In the event of a problem with warranty service or performance, you may be able to go to a small claims court, a State court, or a Federal District Court.

This warranty is void if equipment is not installed and operated according to instructions. It does not apply to damage caused by abuse, accident, neglect, freezing, fire, or other abnormal conditions beyond the company's control. This warranty is void on any part from which the manufacturing date has been removed or made illegible.

Benefits will be provided by various types of RainSoft equipment when installed and operated according to the manufacturer's recommendations. Operational, maintenance and replacement requirements are essential for the product to perform as advertised. All claims are based on the best available information at the time of printing. Manufacturer makes no representations as to the suitability of this equipment for a particular application. Buyer relies entirely on the dealer's recommendations in the purchase of this equipment.

Independent RainSoft dealers may include, together with your RainSoft product, a product or component that is not manufactured by RainSoft or their parent company, AWTP, LLC. Any non-RainSoft product may be covered by the manufacturer of that product, and is not covered by the RainSoft warranty. AWTP, LLC does not warrant that your RainSoft product and the non-RainSoft product will perform properly when used together, and assumes no liability therefore.

RainSoft Division of Aquion Water Treatment Products  
2080 East Lunt Avenue  
Elk Grove Village, Illinois 60007 USA

# Valve Exploded View

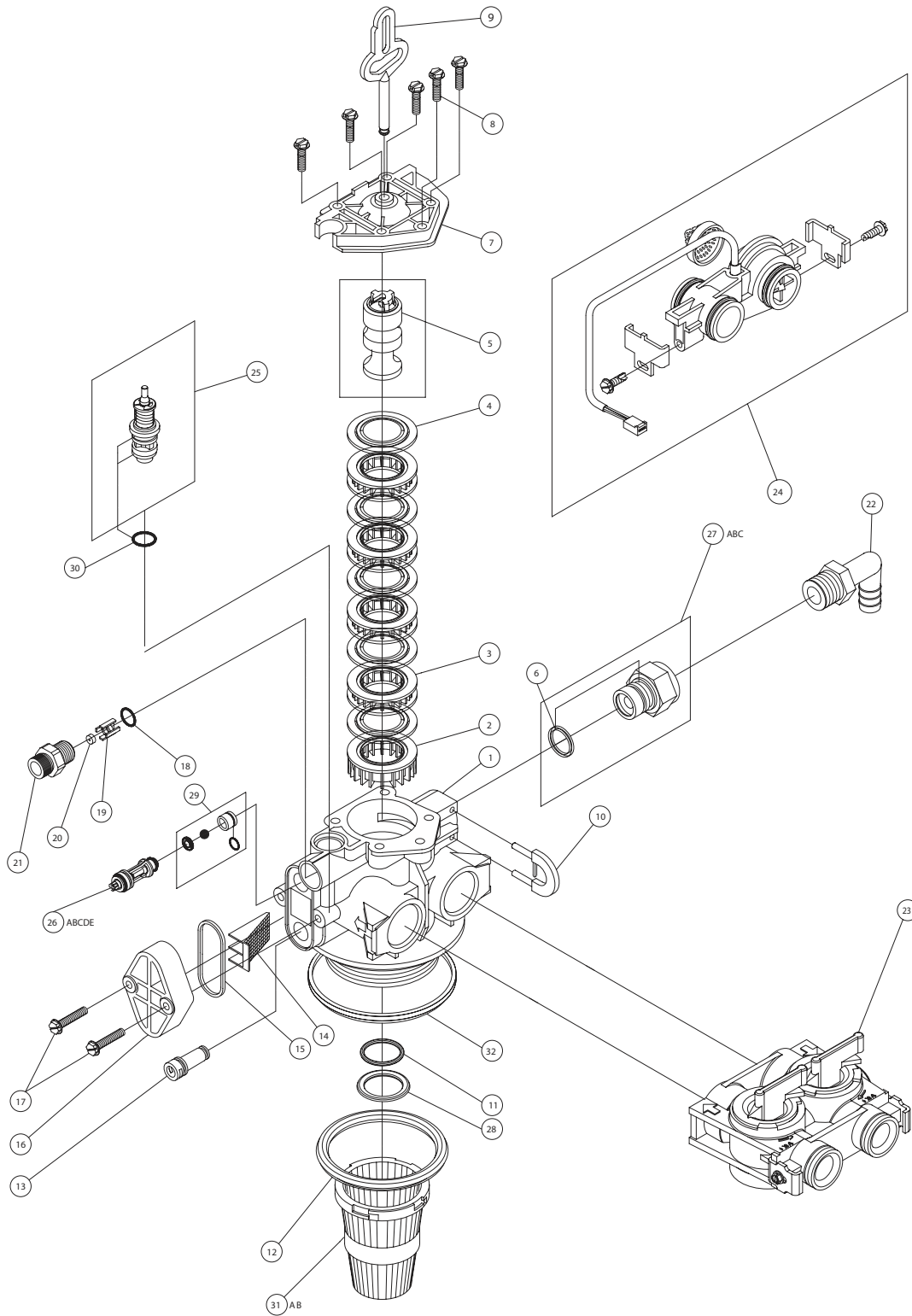

# Valve Parts List

Item	Quantity	Part Number	Description
1	1	17863	Composite valve body
2	1	17864	Spacer end
3	4	17865	Internal spacer
4	5	17866	Internal seal
5	1	18160	Retainer & down flow piston
6	1	10258	O-ring - 017
7	1	17869	End plug assembly
8	5	17870	10-24 x .812 screw hex washer head
9	1	17871	Piston rod
10	1	17887	Retainer drain
11	1	17888	O-ring - 121
12	1	17889	O-ring - 336
13	1	17617	Injector plug assembly
14	1	17948	Injector screen
15	1	17949	Injector seal
16	1	17950	Injector cap
17	2	17951	Screw hex washer head 10-24 x 1.0
18	1	17958	O-ring - 015
19	1	17953	Retainer blfc button
20	1	17954	Flow control washer 0.25 gpm
21	1	17957	Adapter blfc 0.25 gpm
22	1	17939	1/2 npt x 1/2 barb poly elbow
23	1	17557	Composite bypass valve
24A	1	17560	3/4" coupling adapter assembly
24B	1	17558	Turbine meter assembly with cable
25	1	17812	Refill shut-off assembly
26A	1	17893	#00 injector assembly
26B	1	17947	#0 injector assembly
26C	1	18194	#1 injector assembly
26D	1	19318	#2 injector assembly
26E	1	19393	#3 injector assembly
27A	1	17991	1.5 drain line flow control assembly
27B	1	17992	2.0 drain line flow control assembly
27C	1	17994	3.0 drain line flow control assembly
28	1	18445	Riser pipe retainer o-ring
29	1	19739	Check ball cage assembly
30	2	13329	O-ring - 014
31A	1	17941	Diffuser upper basket 1 x .008 red
31B	1	18985	Diffuser upper basket 1 x .02 white
32	1	19328	Tank retainer seal

# Control Exploded View

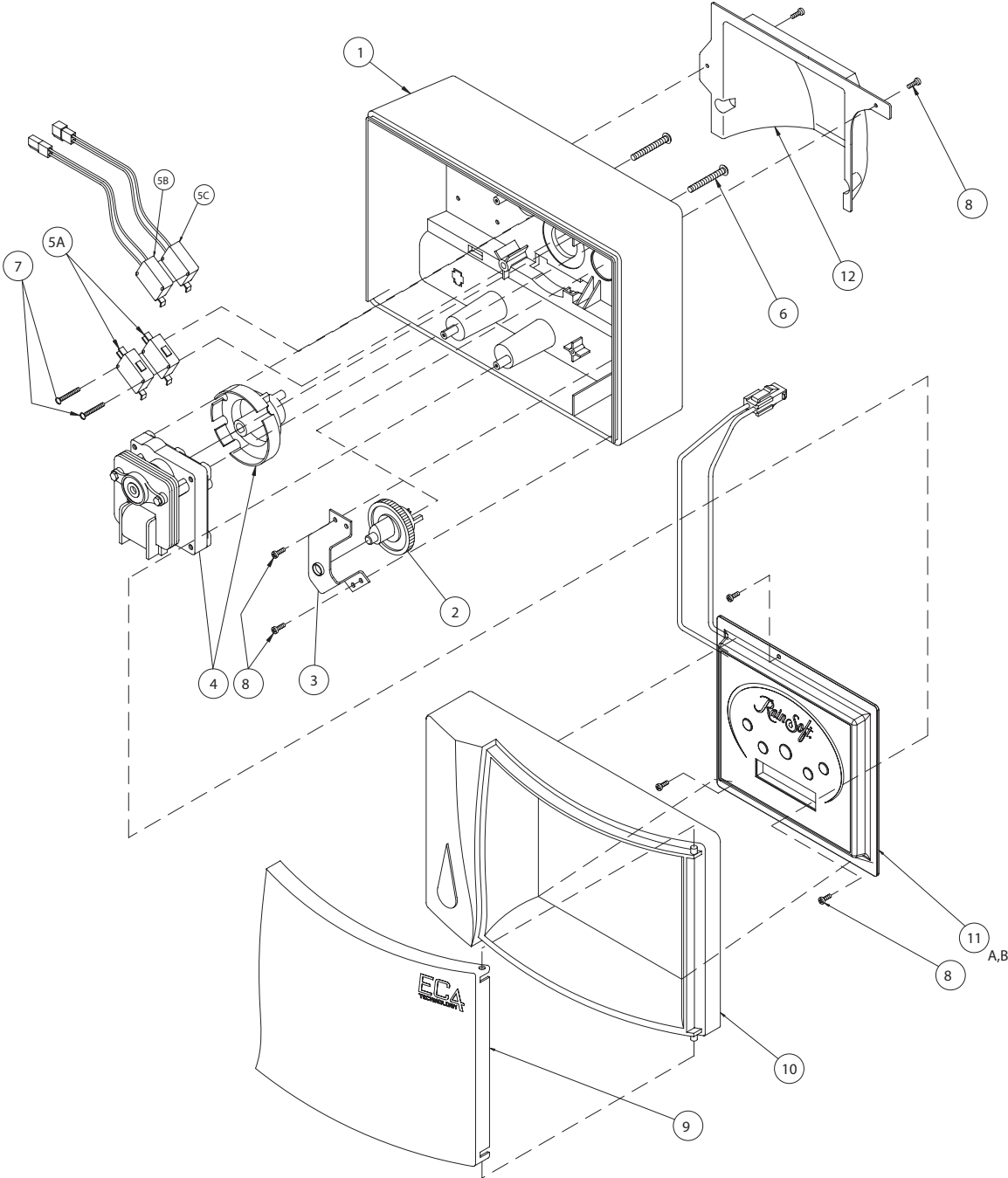

## Control Parts List

Item	Quantity	Part Number	Description
1	1	17487	Rear housing
2	1	17501	Brine cam gear
3	1	17492	Brine cam gear bracket
4	1	17537	Valve motor w/computer cam 24v 50/60 hz
5A	2	17526	Switch 45 deg actuator gold contact (indoor)
5B	2	19536	Sealed switch C-NC male connector red (outdoor)
5C	2	19537	Sealed switch C-NO female connector brown (outdoor)
6	2	17548	10-32 x 1.50 screw pan h phil ss
7	2	18135	4 x 1.25 screw slotted hex washer type 25
8	5	17542	4-20 x .375 screw pan h phil ss
9	1	17853	Front door housing gold
10	1	17855	Front housing gold
11	11	19701	EC4 computer assembly
12	2	17542	4-20 x .375 screw pan h phil ss
13	1	17490	Rear housing cover
14	1	19693	EC4 PCB computer wire harness

## EC4 75 CV

### DEMAND INITIATED TREATMENT SYSTEM

- SERVICE FLOW RATE = 9.3 GPM (35.2 LPM)
- DRAIN FLOW RATE: 1.5 GPM (5.7 LPM)
- PSI DROP @ FLOW RATE: 15.0 psi (1.1 kgf/cm<sup>2</sup>)
- OPERATING PSI OF SUPPLY: 20 psi - 120 psi (1.47 - 8.45 kgf/cm<sup>2</sup>)
- OPERATING TEMPERATURE: 40° F - 100° F (4.4° C - 38° C)
- ELECTRICAL: 24 VAC, 50/60 Hz (COMPUTER)
- SALT PER REGENERATION: VARIABLE
- EFFICIENCY: 4,470 GRAINS/LBS. SALT @ 3.0 LBS. DOSAGE

**CAPACITY AND SALT SETTINGS**

CAPACITY	SALT
13,400 GRAINS	@ 3.0 LBS. OF SALT
24,000 GRAINS	@ 7.5 LBS. OF SALT
28,100 GRAINS	@ 11.2 LBS. OF SALT

**LIST OF CONTAMINANTS REDUCED**

CONTAMINANT	USEPA MCL
BARIUM*	2 PPM
RADIUM 226/228*	5 PCI/L

NSF/ANSI STANDARD 44 TEST CONDITIONS: 35 ± 5 psi, 65 ± 10°F, pH 7.5 ± 0.5 at service flow rate

\*HARDNESS WAS USED AS A SURROGATE FOR BARIUM AND RADIUM REDUCTION CLAIMS PER NSF/ANSI STANDARD 44.

**SOFTENING PERFORMANCE TEST**

CHALLENGE	AVERAGE INFLUENT LEVEL	AVERAGE EFFLUENT LEVEL
HARDNESS	350 PPM	9 PPM

NSF/ANSI STANDARD 44 TEST CONDITIONS: 35 ± 5 psi, 65 ± 10°F, pH 7.5 ± 0.5 at service flow rate

**ADDITIONAL NOTES**

- THE LIST OF SUBSTANCES WHICH THIS TREATMENT DEVICE REDUCES DOES NOT NECESSARILY MEAN THAT THESE SUBSTANCES ARE PRESENT IN YOUR WATER SUPPLY.
- ACTUAL RESULTS MAY VARY DUE TO LOCAL WATER CONDITIONS.
- AN EFFICIENCY RATED WATER SOFTENER IS A DEMAND INITIATED REGENERATION SOFTENER, WHICH ALSO COMPLIES WITH SPECIFIC PERFORMANCE SPECIFICATIONS INTENDED TO MINIMIZE THE AMOUNT OF REGENERATE BRINE AND WATER USED IN ITS OPERATION AND WILL ACHIEVE A RATING OF NOT LESS THAN 3,350 GRAINS OF TOTAL HARDNESS EXCHANGE PER POUND OF SODIUM CHLORIDE SALT AND SHALL NOT DELIVER MORE SALT THAN ITS LISTED RATING. THE EFFICIENCY IS MEASURED BY A LABORATORY TEST DESCRIBED IN NSF/ANSI 44. THE TEST REPRESENTS THE MAXIMUM POSSIBLE EFFICIENCY THAT THE SYSTEM CAN ACHIEVE. OPERATIONAL EFFICIENCY IS THE ACTUAL EFFICIENCY ACHIEVED AFTER THE SYSTEM HAS BEEN INSTALLED AND IS TYPICALLY LESS THAN THE TESTED EFFICIENCY DUE TO INDIVIDUAL APPLICATION FACTORS INCLUDING WATER HARDNESS, WATER USAGE, AND OTHER CONTAMINANTS THAT REDUCE THE SOFTENERS CAPACITY.
- A WATER SOFTENER IS NOT INTENDED TO BE USED FOR TREATING WATER THAT IS MICROBIOLOGICALLY UNSAFE OR OF UNKNOWN QUALITY WITHOUT ADEQUATE DISINFECTION BEFORE AND AFTER THE SYSTEM.
- EFFICIENCY OF THE CONDITIONER IS VALID ONLY AT THE STATED SALT DOSAGE.

THE SYSTEM SHOULD BE INSTALLED IN AN AREA NOT AFFECTED BY EXTREME HEAT, COLD, OR THE ELEMENTS.

THIS SYSTEM MUST BE INSTALLED IN ACCORDANCE WITH ALL APPLICABLE STATE AND LOCAL LAWS AND REGULATIONS.

DO NOT INSTALL SYSTEM WHERE WATER IS MICROBIOLOGICALLY UNSAFE OR OF UNKNOWN QUALITY WITHOUT ADEQUATE DISINFECTION BEFORE OR AFTER THE SYSTEM.

THE SYSTEM CONTAINS AN ION-EXCHANGE MEDIA FOR REMOVING LISTED CONTAMINANTS AND MUST BE REGENERATED PERIODICALLY. PLEASE REFER TO THE OWNERS MANUAL TO DETERMINE THE FREQUENCY OF REGENERATIONS.

PLAIN, WHITE BLOCK SALT IS RECOMMENDED FOR THIS SYSTEM. IF BLOCK SALT IS NOT AVAILABLE, A CLEAN, COARSE OR EXTRA COARSE ROCK OR SOLAR SALT MAY BE USED. DO NOT USE GRANULATED SALT. CONSULT YOUR RAINSOFT DEALER FOR POTASSIUM CHLORIDE USE.

YOUR LOCAL DEALER IS AVAILABLE FOR SERVICE AND WARRANTY PART REPLACEMENTS.

STATE OF CALIFORNIA DEPARTMENT OF HEALTH SERVICES CERTIFICATE NUMBER 06-1803



TESTED AND CERTIFIED BY THE WQA TO NSF/ANSI STANDARD 44 FOR THE SPECIFIC PERFORMANCE CLAIMS AS VERIFIED AND SUBSTANTIATED BY TEST DATA

SEE THE OWNERS MANUAL FOR GENERAL OPERATION AND MAINTENANCE REQUIREMENTS.

SEE WARRANTY CARD FOR SPECIFIC WARRANTY INFORMATION.

**IMPORTANT NOTICE**

READ THIS PERFORMANCE DATA SHEET AND COMPARE THE CAPABILITIES OF THIS UNIT WITH YOUR ACTUAL WATER TREATMENT NEEDS. IT IS RECOMMENDED THAT BEFORE PURCHASING A WATER TREATMENT UNIT, YOU HAVE YOUR WATER SUPPLY TESTED TO DETERMINE YOUR ACTUAL WATER TREATMENT NEEDS.



**EC4 75 CV**  
DEMAND INITIATED TREATMENT SYSTEM

State of California  
Department of Health Services  
Water Treatment Device  
Certificate Number

06 - 1803

Date Issued: July 28, 2006

<u>Trademark/Model Designation</u>	<u>Replacement Elements</u>
EC4 75 CV	N/A
<u>Manufacturer: RainSoft Div of Aquion Water Treatment Products</u>	

The water treatment device(s) listed on this certificate have met the testing requirements pursuant to Section 116830 of the Health and Safety Code for the following health related contaminants:

<u>Microbiological Contaminants and Turbidity</u>	<u>Inorganic/Radiological Contaminants</u>
None	Barium
<u>Organic Contaminants</u>	Radium 226/228
None	

Rated Service Capacity: N/A	Rated Service Flow: 9.3 gpm
-----------------------------	-----------------------------

Conditions of Certification:  
Do not use with water that is microbiologically unsafe or of unknown quality, without adequate disinfection before or after the system.

## EC4 100 CV

### DEMAND INITIATED TREATMENT SYSTEM

- SERVICE FLOW RATE = 10.0 GPM (37.8 LPM)
- DRAIN FLOW RATE: 2.0 GPM (7.6 LPM)
- PSI DROP @ FLOW RATE: 12.0 psi (0.9 kgf/cm<sup>2</sup>)
- OPERATING PSI OF SUPPLY: 20 psi - 120 psi (1.47 - 8.45 kgf/cm<sup>2</sup>)
- OPERATING TEMPERATURE: 40° F - 100° F (4.4° C - 38° C)
- ELECTRICAL: 24 VAC, 50/60 Hz (COMPUTER)
- SALT PER REGENERATION: VARIABLE
- EFFICIENCY: 4,970 GRAINS/LBS. SALT @ 3.0 LBS. DOSAGE

**CAPACITY AND SALT SETTINGS**

CAPACITY	SALT
14,900 GRAINS	@ 3.0 LBS. OF SALT
32,300 GRAINS	@ 10.0 LBS. OF SALT
37,700 GRAINS	@ 15.0 LBS. OF SALT

**LIST OF CONTAMINANTS REDUCED**

CONTAMINANT	USEPA MCL
BARIUM*	2 PPM
RADIUM 226/228*	5 PCI/L

NSF/ANSI STANDARD 44 TEST CONDITIONS: 35 ± 5 psi, 65 ± 10°F, pH 7.5 ± 0.5 at service flow rate

\*HARDNESS WAS USED AS A SURROGATE FOR BARIUM AND RADIUM REDUCTION CLAIMS PER NSF/ANSI STANDARD 44.

**SOFTENING PERFORMANCE TEST**

CHALLENGE	AVERAGE INFLUENT LEVEL	AVERAGE EFFLUENT LEVEL
HARDNESS	324 PPM	15 PPM

NSF/ANSI STANDARD 44 TEST CONDITIONS: 35 ± 5 psi, 65 ± 10°F, pH 7.5 ± 0.5 at service flow rate

**ADDITIONAL NOTES**

- THE LIST OF SUBSTANCES WHICH THIS TREATMENT DEVICE REDUCES DOES NOT NECESSARILY MEAN THAT THESE SUBSTANCES ARE PRESENT IN YOUR WATER SUPPLY.
- ACTUAL RESULTS MAY VARY DUE TO LOCAL WATER CONDITIONS.
- AN EFFICIENCY RATED WATER SOFTENER IS A DEMAND INITIATED REGENERATION SOFTENER, WHICH ALSO COMPLIES WITH SPECIFIC PERFORMANCE SPECIFICATIONS INTENDED TO MINIMIZE THE AMOUNT OF REGENERATE BRINE AND WATER USED IN ITS OPERATION AND WILL ACHIEVE A RATING OF NOT LESS THAN 3,350 GRAINS OF TOTAL HARDNESS EXCHANGE PER POUND OF SODIUM CHLORIDE SALT AND SHALL NOT DELIVER MORE SALT THAN ITS LISTED RATING. THE EFFICIENCY IS MEASURED BY A LABORATORY TEST DESCRIBED IN NSF/ANSI 44. THE TEST REPRESENTS THE MAXIMUM POSSIBLE EFFICIENCY THAT THE SYSTEM CAN ACHIEVE. OPERATIONAL EFFICIENCY IS THE ACTUAL EFFICIENCY ACHIEVED AFTER THE SYSTEM HAS BEEN INSTALLED AND IS TYPICALLY LESS THAN THE TESTED EFFICIENCY DUE TO INDIVIDUAL APPLICATION FACTORS INCLUDING WATER HARDNESS, WATER USAGE, AND OTHER CONTAMINANTS THAT REDUCE THE SOFTENERS CAPACITY.
- A WATER SOFTENER IS NOT INTENDED TO BE USED FOR TREATING WATER THAT IS MICROBIOLOGICALLY UNSAFE OR OF UNKNOWN QUALITY WITHOUT ADEQUATE DISINFECTION BEFORE AND AFTER THE SYSTEM.
- EFFICIENCY OF THE CONDITIONER IS VALID ONLY AT THE STATED SALT DOSAGE.

THE SYSTEM SHOULD BE INSTALLED IN AN AREA NOT AFFECTED BY EXTREME HEAT, COLD, OR THE ELEMENTS.

THIS SYSTEM MUST BE INSTALLED IN ACCORDANCE WITH ALL APPLICABLE STATE AND LOCAL LAWS AND REGULATIONS.

DO NOT INSTALL SYSTEM WHERE WATER IS MICROBIOLOGICALLY UNSAFE OR OF UNKNOWN QUALITY WITHOUT ADEQUATE DISINFECTION BEFORE OR AFTER THE SYSTEM.

THE SYSTEM CONTAINS AN ION-EXCHANGE MEDIA FOR REMOVING LISTED CONTAMINANTS AND MUST BE REGENERATED PERIODICALLY. PLEASE REFER TO THE OWNERS MANUAL TO DETERMINE THE FREQUENCY OF REGENERATIONS.

PLAIN, WHITE BLOCK SALT IS RECOMMENDED FOR THIS SYSTEM. IF BLOCK SALT IS NOT AVAILABLE, A CLEAN, COARSE OR EXTRA COARSE ROCK OR SOLAR SALT MAY BE USED. DO NOT USE GRANULATED SALT. CONSULT YOUR RAINSOFT DEALER FOR POTASSIUM CHLORIDE USE.

YOUR LOCAL DEALER IS AVAILABLE FOR SERVICE AND WARRANTY PART REPLACEMENTS.

STATE OF CALIFORNIA DEPARTMENT OF HEALTH SERVICES CERTIFICATE NUMBER 06-1802



TESTED AND CERTIFIED BY THE WQA TO NSF/ANSI STANDARD 44 FOR THE SPECIFIC PERFORMANCE CLAIMS AS VERIFIED AND SUBSTANTIATED BY TEST DATA

SEE THE OWNERS MANUAL FOR GENERAL OPERATION AND MAINTENANCE REQUIREMENTS.

SEE WARRANTY CARD FOR SPECIFIC WARRANTY INFORMATION.

**IMPORTANT NOTICE**

READ THIS PERFORMANCE DATA SHEET AND COMPARE THE CAPABILITIES OF THIS UNIT WITH YOUR ACTUAL WATER TREATMENT NEEDS. IT IS RECOMMENDED THAT BEFORE PURCHASING A WATER TREATMENT UNIT, YOU HAVE YOUR WATER SUPPLY TESTED TO DETERMINE YOUR ACTUAL WATER TREATMENT NEEDS.



**EC4 100 CV**  
DEMAND INITIATED TREATMENT SYSTEM

State of California  
Department of Health Services  
Water Treatment Device  
Certificate Number

06 - 1802

Date Issued: July 28, 2006

<u>Trademark/Model Designation</u>	<u>Replacement Elements</u>
EC4 100 CV	N/A
<u>Manufacturer: RainSoft Div of Aquion Water Treatment Products</u>	

The water treatment device(s) listed on this certificate have met the testing requirements pursuant to Section 116830 of the Health and Safety Code for the following health related contaminants:

<u>Microbiological Contaminants and Turbidity</u>	<u>Inorganic/Radiological Contaminants</u>
None	Barium
<u>Organic Contaminants</u>	Radium 226/228
None	

Rated Service Capacity: N/A	Rated Service Flow: 10.0 gpm
-----------------------------	------------------------------

Conditions of Certification:  
Do not use with water that is microbiologically unsafe or of unknown quality, without adequate disinfection before or after the system.

## EC4 150 CV

### DEMAND INITIATED TREATMENT SYSTEM

- SERVICE FLOW RATE = 10.4 GPM (39.4 LPM)
- DRAIN FLOW RATE: 2.0 GPM (7.6 LPM)
- PSI DROP @ FLOW RATE: 15.0 psi (1.1 kgf/cm<sup>2</sup>)
- OPERATING PSI OF SUPPLY: 20 psi - 120 psi (1.47 - 8.45 kgf/cm<sup>2</sup>)
- OPERATING TEMPERATURE: 40° F - 100° F (4.4° C - 38° C)
- ELECTRICAL: 24 VAC, 50/60 Hz (COMPUTER)
- SALT PER REGENERATION: VARIABLE
- EFFICIENCY: 4,970 GRAINS/LBS. SALT @ 4.5 LBS. DOSAGE

**CAPACITY AND SALT SETTINGS**

CAPACITY	SALT
22,400 GRAINS	@ 4.5 LBS. OF SALT
48,500 GRAINS	@ 15.0 LBS. OF SALT
56,600 GRAINS	@ 22.5 LBS. OF SALT

**LIST OF CONTAMINANTS REDUCED**

CONTAMINANT	USEPA MCL
BARIUM*	2 PPM
RADIUM 226/228*	5 PCI/L

NSF/ANSI STANDARD 44 TEST CONDITIONS: 35 ± 5 psi, 65 ± 10°F, pH 7.5 ± 0.5 at service flow rate

\*HARDNESS WAS USED AS A SURROGATE FOR BARIUM AND RADIUM REDUCTION CLAIMS PER NSF/ANSI STANDARD 44.

**SOFTENING PERFORMANCE TEST**

CHALLENGE	AVERAGE INFLUENT LEVEL	AVERAGE EFFLUENT LEVEL
HARDNESS	324 PPM	15 PPM

NSF/ANSI STANDARD 44 TEST CONDITIONS: 35 ± 5 psi, 65 ± 10°F, pH 7.5 ± 0.5 at service flow rate

**ADDITIONAL NOTES**

- THE LIST OF SUBSTANCES WHICH THIS TREATMENT DEVICE REDUCES DOES NOT NECESSARILY MEAN THAT THESE SUBSTANCES ARE PRESENT IN YOUR WATER SUPPLY.
- ACTUAL RESULTS MAY VARY DUE TO LOCAL WATER CONDITIONS.
- AN EFFICIENCY RATED WATER SOFTENER IS A DEMAND INITIATED REGENERATION SOFTENER, WHICH ALSO COMPLIES WITH SPECIFIC PERFORMANCE SPECIFICATIONS INTENDED TO MINIMIZE THE AMOUNT OF REGENERATE BRINE AND WATER USED IN ITS OPERATION AND WILL ACHIEVE A RATING OF NOT LESS THAN 3,350 GRAINS OF TOTAL HARDNESS EXCHANGE PER POUND OF SODIUM CHLORIDE SALT AND SHALL NOT DELIVER MORE SALT THAN ITS LISTED RATING. THE EFFICIENCY IS MEASURED BY A LABORATORY TEST DESCRIBED IN NSF/ANSI 44. THE TEST REPRESENTS THE MAXIMUM POSSIBLE EFFICIENCY THAT THE SYSTEM CAN ACHIEVE. OPERATIONAL EFFICIENCY IS THE ACTUAL EFFICIENCY ACHIEVED AFTER THE SYSTEM HAS BEEN INSTALLED AND IS TYPICALLY LESS THAN THE TESTED EFFICIENCY DUE TO INDIVIDUAL APPLICATION FACTORS INCLUDING WATER HARDNESS, WATER USAGE, AND OTHER CONTAMINANTS THAT REDUCE THE SOFTENERS CAPACITY.
- A WATER SOFTENER IS NOT INTENDED TO BE USED FOR TREATING WATER THAT IS MICROBIOLOGICALLY UNSAFE OR OF UNKNOWN QUALITY WITHOUT ADEQUATE DISINFECTION BEFORE AND AFTER THE SYSTEM.
- EFFICIENCY OF THE CONDITIONER IS VALID ONLY AT THE STATED SALT DOSAGE.

THE SYSTEM SHOULD BE INSTALLED IN AN AREA NOT AFFECTED BY EXTREME HEAT, COLD, OR THE ELEMENTS.

THIS SYSTEM MUST BE INSTALLED IN ACCORDANCE WITH ALL APPLICABLE STATE AND LOCAL LAWS AND REGULATIONS.

DO NOT INSTALL SYSTEM WHERE WATER IS MICROBIOLOGICALLY UNSAFE OR OF UNKNOWN QUALITY WITHOUT ADEQUATE DISINFECTION BEFORE OR AFTER THE SYSTEM.

THE SYSTEM CONTAINS AN ION-EXCHANGE MEDIA FOR REMOVING LISTED CONTAMINANTS AND MUST BE REGENERATED PERIODICALLY. PLEASE REFER TO THE OWNERS MANUAL TO DETERMINE THE FREQUENCY OF REGENERATIONS.

PLAIN, WHITE BLOCK SALT IS RECOMMENDED FOR THIS SYSTEM. IF BLOCK SALT IS NOT AVAILABLE, A CLEAN, COARSE OR EXTRA COARSE ROCK OR SOLAR SALT MAY BE USED. DO NOT USE GRANULATED SALT. CONSULT YOUR RAINSOFT DEALER FOR POTASSIUM CHLORIDE USE.

YOUR LOCAL DEALER IS AVAILABLE FOR SERVICE AND WARRANTY PART REPLACEMENTS.

STATE OF CALIFORNIA DEPARTMENT OF HEALTH SERVICES  
CERTIFICATE NUMBER 06-1801



TESTED AND CERTIFIED BY THE WQA TO NSF/ANSI STANDARD 44 FOR THE SPECIFIC PERFORMANCE CLAIMS AS VERIFIED AND SUBSTANTIATED BY TEST DATA

SEE THE OWNERS MANUAL FOR GENERAL OPERATION AND MAINTENANCE REQUIREMENTS.

SEE WARRANTY CARD FOR SPECIFIC WARRANTY INFORMATION.

**IMPORTANT NOTICE**

READ THIS PERFORMANCE DATA SHEET AND COMPARE THE CAPABILITIES OF THIS UNIT WITH YOUR ACTUAL WATER TREATMENT NEEDS. IT IS RECOMMENDED THAT BEFORE PURCHASING A WATER TREATMENT UNIT, YOU HAVE YOUR WATER SUPPLY TESTED TO DETERMINE YOUR ACTUAL WATER TREATMENT NEEDS.

**EC4 150 CV**  
DEMAND INITIATED TREATMENT SYSTEM

State of California  
Department of Health Services  
Water Treatment Device  
Certificate Number

06 - 1801

Date Issued: July 28, 2006

<u>Trademark/Model Designation</u>	<u>Replacement Elements</u>
EC4 150 CV	N/A
<u>Manufacturer: RainSoft Div of Aquion Water Treatment Products</u>	

The water treatment device(s) listed on this certificate have met the testing requirements pursuant to Section 116830 of the Health and Safety Code for the following health related contaminants:

Microbiological Contaminants and Turbidity

None

Inorganic/Radiological Contaminants

Barium  
Radium 226/228

Organic Contaminants

None

Rated Service Capacity: N/A

Rated Service Flow: 10.4 gpm

Conditions of Certification:

Do not use with water that is microbiologically unsafe or of unknown quality, without adequate disinfection before or after the system.

## EC4-CAB 60 CV

### DEMAND INITIATED TREATMENT SYSTEM

- SERVICE FLOW RATE = 9.5 GPM (36.0 LPM)
- DRAIN FLOW RATE: 2.0 GPM (7.6 LPM)
- PSI DROP @ FLOW RATE: 10.0 psi (0.7 kgf/cm<sup>2</sup>)
- OPERATING PSI OF SUPPLY: 20 psi - 120 psi (1.47 - 8.45 kgf/cm<sup>2</sup>)
- OPERATING TEMPERATURE: 40° F - 100° F (4.4° C - 38° C)
- ELECTRICAL: 24 VAC, 50/60 Hz (COMPUTER)
- SALT PER REGENERATION: VARIABLE
- EFFICIENCY: 4,470 GRAINS/LBS. SALT @ 2.4 LBS. DOSAGE

#### CAPACITY AND SALT SETTINGS

CAPACITY	SALT
10,700 GRAINS	@ 2.4 LBS. OF SALT
19,200 GRAINS	@ 6.0 LBS. OF SALT
22,500 GRAINS	@ 9.0 LBS. OF SALT

#### LIST OF CONTAMINANTS REDUCED

CONTAMINANT	USEPA MCL
BARIUM*	2 PPM
RADIUM 226/228*	5 PCI/L

NSF/ANSI STANDARD 44 TEST CONDITIONS: 35 ± 5 psi, 65 ± 10°F, pH 7.5 ± 0.5 at service flow rate

\*HARDNESS WAS USED AS A SURROGATE FOR BARIUM AND RADIUM REDUCTION CLAIMS PER NSF/ANSI STANDARD 44.

#### SOFTENING PERFORMANCE TEST

CHALLENGE	AVERAGE INFLUENT LEVEL	AVERAGE EFFLUENT LEVEL
HARDNESS	350 PPM	9 PPM

NSF/ANSI STANDARD 44 TEST CONDITIONS: 35 ± 5 psi, 65 ± 10°F, pH 7.5 ± 0.5 at service flow rate

#### ADDITIONAL NOTES

- THE LIST OF SUBSTANCES WHICH THIS TREATMENT DEVICE REDUCES DOES NOT NECESSARILY MEAN THAT THESE SUBSTANCES ARE PRESENT IN YOUR WATER SUPPLY.
- ACTUAL RESULTS MAY VARY DUE TO LOCAL WATER CONDITIONS.
- AN EFFICIENCY RATED WATER SOFTENER IS A DEMAND INITIATED REGENERATION SOFTENER, WHICH ALSO COMPLIES WITH SPECIFIC PERFORMANCE SPECIFICATIONS INTENDED TO MINIMIZE THE AMOUNT OF REGENERATE BRINE AND WATER USED IN ITS OPERATION AND WILL ACHIEVE A RATING OF NOT LESS THAN 3,350 GRAINS OF TOTAL HARDNESS EXCHANGE PER POUND OF SODIUM CHLORIDE SALT AND SHALL NOT DELIVER MORE SALT THAN ITS LISTED RATING. THE EFFICIENCY IS MEASURED BY A LABORATORY TEST DESCRIBED IN NSF/ANSI 44. THE TEST REPRESENTS THE MAXIMUM POSSIBLE EFFICIENCY THAT THE SYSTEM CAN ACHIEVE. OPERATIONAL EFFICIENCY IS THE ACTUAL EFFICIENCY ACHIEVED AFTER THE SYSTEM HAS BEEN INSTALLED AND IS TYPICALLY LESS THAN THE TESTED EFFICIENCY DUE TO INDIVIDUAL APPLICATION FACTORS INCLUDING WATER HARDNESS, WATER USAGE, AND OTHER CONTAMINANTS THAT REDUCE THE SOFTENERS CAPACITY.
- A WATER SOFTENER IS NOT INTENDED TO BE USED FOR TREATING WATER THAT IS MICROBIOLOGICALLY UNSAFE OR OF UNKNOWN QUALITY WITHOUT ADEQUATE DISINFECTION BEFORE AND AFTER THE SYSTEM.
- EFFICIENCY OF THE CONDITIONER IS VALID ONLY AT THE STATED SALT DOSAGE.

#### IMPORTANT NOTICE

READ THIS PERFORMANCE DATA SHEET AND COMPARE THE CAPABILITIES OF THIS UNIT WITH YOUR ACTUAL WATER TREATMENT NEEDS. IT IS RECOMMENDED THAT BEFORE PURCHASING A WATER TREATMENT UNIT, YOU HAVE YOUR WATER SUPPLY TESTED TO DETERMINE YOUR ACTUAL WATER TREATMENT NEEDS.



TESTED AND CERTIFIED BY THE WQA TO NSF/ANSI STANDARD 44 FOR THE SPECIFIC PERFORMANCE CLAIMS AS VERIFIED AND SUBSTANTIATED BY TEST DATA

SEE THE OWNERS MANUAL FOR GENERAL OPERATION AND MAINTENANCE REQUIREMENTS.

SEE WARRANTY CARD FOR SPECIFIC WARRANTY INFORMATION.



DEMAND INITIATED

WATER TREATMENT SYSTEM

CALIFORNIA PERFORMANCE DATA SHEET  
Page 2 of 2

**EC4-CAB 60 CV**  
DEMAND INITIATED TREATMENT SYSTEM

State of California  
Department of Health Services  
Water Treatment Device  
Certificate Number

06 - 1805

Date Issued: July 28, 2006

Trademark/Model Designation

EC4-CAB 60 CV

Replacement Elements

N/A

Manufacturer: RainSoft Div of Aquion Water Treatment Products

The water treatment device(s) listed on this certificate have met the testing requirements pursuant to Section 116830 of the Health and Safety Code for the following health related contaminants:

Microbiological Contaminants and Turbidity

None

Inorganic/Radiological Contaminants

Barium

Radium 226/228

Organic Contaminants

None

Rated Service Capacity: N/A

Rated Service Flow: 9.5 gpm

Conditions of Certification:

Do not use with water that is microbiologically unsafe or of unknown quality, without adequate disinfection before or after the system.

## EC4-CAB 100 CV

### DEMAND INITIATED TREATMENT SYSTEM

- SERVICE FLOW RATE = 10.0 GPM (37.8 LPM)
- DRAIN FLOW RATE: 2.0 GPM (7.6 LPM)
- PSI DROP @ FLOW RATE: 12.0 psi (0.85 kgf/cm<sup>2</sup>)
- OPERATING PSI OF SUPPLY: 20 psi - 120 psi (1.47 - 8.45 kgf/cm<sup>2</sup>)
- OPERATING TEMPERATURE: 40° F - 100° F (4.4° C - 38° C)
- ELECTRICAL: 24 VAC, 50/60 Hz (COMPUTER)
- SALT PER REGENERATION: VARIABLE
- EFFICIENCY: 4,970 GRAINS/LBS. SALT @ 3.0 LBS. DOSAGE

#### CAPACITY AND SALT SETTINGS

CAPACITY	SALT
14,900 GRAINS	@ 3.0 LBS. OF SALT
32,300 GRAINS	@ 10.0 LBS. OF SALT
37,700 GRAINS	@ 15.0 LBS. OF SALT

#### LIST OF CONTAMINANTS REDUCED

CONTAMINANT	USEPA MCL
BARIUM*	2 PPM
RADIUM 226/228*	5 PCI/L

NSF/ANSI STANDARD 44 TEST CONDITIONS: 35 ± 5 psi, 65 ± 10°F, pH 7.5 ± 0.5 at service flow rate

\*HARDNESS WAS USED AS A SURROGATE FOR BARIUM AND RADIUM REDUCTION CLAIMS PER NSF/ANSI STANDARD 44.

#### SOFTENING PERFORMANCE TEST

CHALLENGE	AVERAGE INFLUENT LEVEL	AVERAGE EFFLUENT LEVEL
HARDNESS	350 PPM	9 PPM

NSF/ANSI STANDARD 44 TEST CONDITIONS: 35 ± 5 psi, 65 ± 10°F, pH 7.5 ± 0.5 at service flow rate

#### ADDITIONAL NOTES

- THE LIST OF SUBSTANCES WHICH THIS TREATMENT DEVICE REDUCES DOES NOT NECESSARILY MEAN THAT THESE SUBSTANCES ARE PRESENT IN YOUR WATER SUPPLY.
- ACTUAL RESULTS MAY VARY DUE TO LOCAL WATER CONDITIONS.
- AN EFFICIENCY RATED WATER SOFTENER IS A DEMAND INITIATED REGENERATION SOFTENER, WHICH ALSO COMPLIES WITH SPECIFIC PERFORMANCE SPECIFICATIONS INTENDED TO MINIMIZE THE AMOUNT OF REGENERATE BRINE AND WATER USED IN ITS OPERATION AND WILL ACHIEVE A RATING OF NOT LESS THAN 3,350 GRAINS OF TOTAL HARDNESS EXCHANGE PER POUND OF SODIUM CHLORIDE SALT AND SHALL NOT DELIVER MORE SALT THAN ITS LISTED RATING. THE EFFICIENCY IS MEASURED BY A LABORATORY TEST DESCRIBED IN NSF/ANSI 44. THE TEST REPRESENTS THE MAXIMUM POSSIBLE EFFICIENCY THAT THE SYSTEM CAN ACHIEVE. OPERATIONAL EFFICIENCY IS THE ACTUAL EFFICIENCY ACHIEVED AFTER THE SYSTEM HAS BEEN INSTALLED AND IS TYPICALLY LESS THAN THE TESTED EFFICIENCY DUE TO INDIVIDUAL APPLICATION FACTORS INCLUDING WATER HARDNESS, WATER USAGE, AND OTHER CONTAMINANTS THAT REDUCE THE SOFTENERS CAPACITY.
- A WATER SOFTENER IS NOT INTENDED TO BE USED FOR TREATING WATER THAT IS MICROBIOLOGICALLY UNSAFE OR OF UNKNOWN QUALITY WITHOUT ADEQUATE DISINFECTION BEFORE AND AFTER THE SYSTEM.
- EFFICIENCY OF THE CONDITIONER IS VALID ONLY AT THE STATED SALT DOSAGE.

THE SYSTEM SHOULD BE INSTALLED IN AN AREA NOT AFFECTED BY EXTREME HEAT, COLD, OR THE ELEMENTS.

THIS SYSTEM MUST BE INSTALLED IN ACCORDANCE WITH ALL APPLICABLE STATE AND LOCAL LAWS AND REGULATIONS.

DO NOT INSTALL SYSTEM WHERE WATER IS MICROBIOLOGICALLY UNSAFE OR OF UNKNOWN QUALITY WITHOUT ADEQUATE DISINFECTION BEFORE OR AFTER THE SYSTEM.

THE SYSTEM CONTAINS AN ION-EXCHANGE MEDIA FOR REMOVING LISTED CONTAMINANTS AND MUST BE REGENERATED PERIODICALLY. PLEASE REFER TO THE OWNERS MANUAL TO DETERMINE THE FREQUENCY OF REGENERATIONS.

PLAIN, WHITE BLOCK SALT IS RECOMMENDED FOR THIS SYSTEM. IF BLOCK SALT IS NOT AVAILABLE, A CLEAN, COARSE OR EXTRA COARSE ROCK OR SOLAR SALT MAY BE USED. DO NOT USE GRANULATED SALT. CONSULT YOUR RAINSOFT DEALER FOR POTASSIUM CHLORIDE USE.

YOUR LOCAL DEALER IS AVAILABLE FOR SERVICE AND WARRANTY PART REPLACEMENTS.

STATE OF CALIFORNIA DEPARTMENT OF HEALTH SERVICES CERTIFICATE NUMBER 06-1804



TESTED AND CERTIFIED BY THE WQA TO NSF/ANSI STANDARD 44 FOR THE SPECIFIC PERFORMANCE CLAIMS AS VERIFIED AND SUBSTANTIATED BY TEST DATA

SEE THE OWNERS MANUAL FOR GENERAL OPERATION AND MAINTENANCE REQUIREMENTS.

SEE WARRANTY CARD FOR SPECIFIC WARRANTY INFORMATION.

#### IMPORTANT NOTICE

READ THIS PERFORMANCE DATA SHEET AND COMPARE THE CAPABILITIES OF THIS UNIT WITH YOUR ACTUAL WATER TREATMENT NEEDS. IT IS RECOMMENDED THAT BEFORE PURCHASING A WATER TREATMENT UNIT, YOU HAVE YOUR WATER SUPPLY TESTED TO DETERMINE YOUR ACTUAL WATER TREATMENT NEEDS.

**EC4-CAB 100 CV**  
DEMAND INITIATED TREATMENT SYSTEM

State of California  
Department of Health Services  
Water Treatment Device  
Certificate Number

06 - 1804

Date Issued: July 28, 2006

Trademark/Model Designation

EC4-CAB 100 CV

Replacement Elements

N/A

Manufacturer: RainSoft Div of Aquion Water Treatment Products

The water treatment device(s) listed on this certificate have met the testing requirements pursuant to Section 116830 of the Health and Safety Code for the following health related contaminants:

Microbiological Contaminants and Turbidity

None

Inorganic/Radiological Contaminants

Barium

Radium 226/228

Organic Contaminants

None

Rated Service Capacity: N/A

Rated Service Flow: 10.0 gpm

Conditions of Certification:

Do not use with water that is microbiologically unsafe or of unknown quality, without adequate disinfection before or after the system.



RainSoft Division of Aquion Water Treatment Products  
2080 East Lunt Avenue  
Elk Grove Village, Illinois 60007  
Main Switchboard: 1.847.437.9400  
Customer Service: 1.800.860.7638  
[www.rainsoft.com](http://www.rainsoft.com)

©2006 RAINSOFT DIVISION OF AWTP, LLC